

# SAMPLE PREPARATION GUIDE

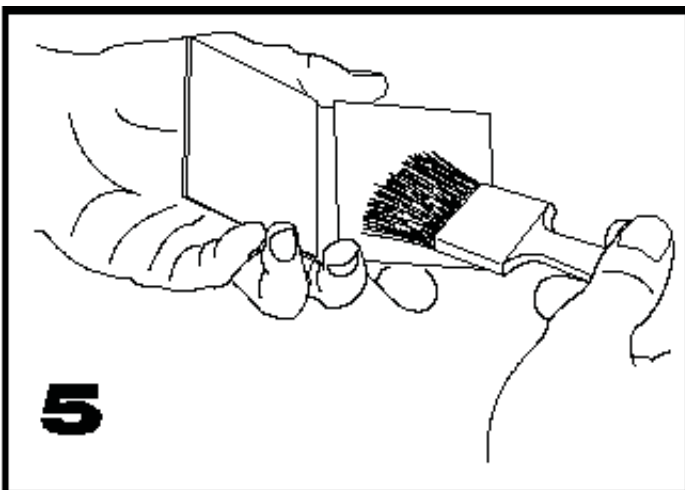
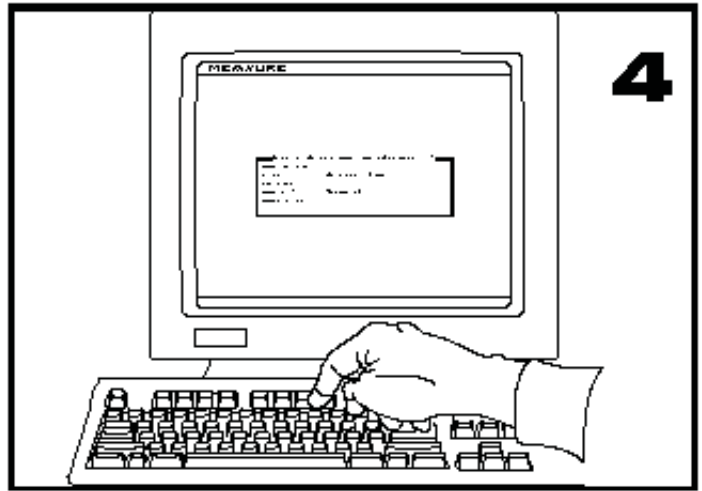
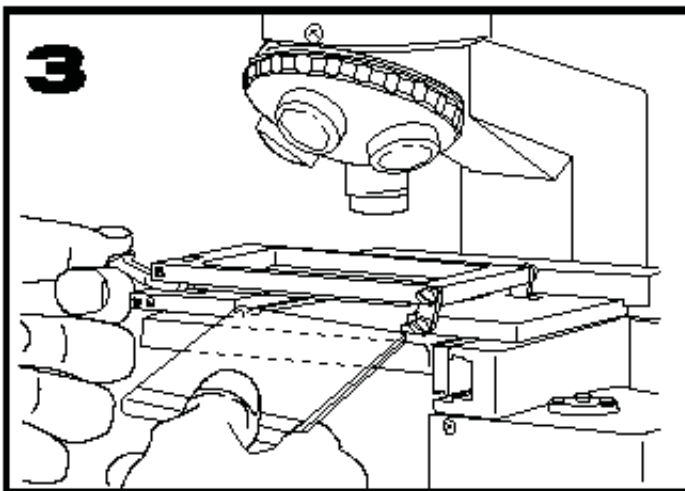
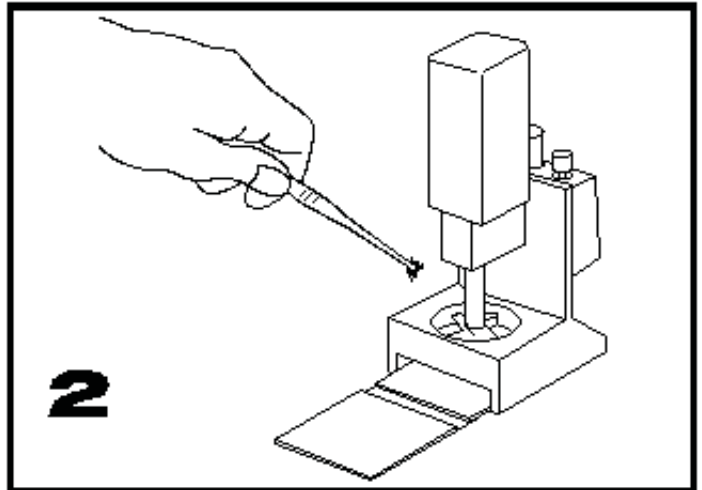
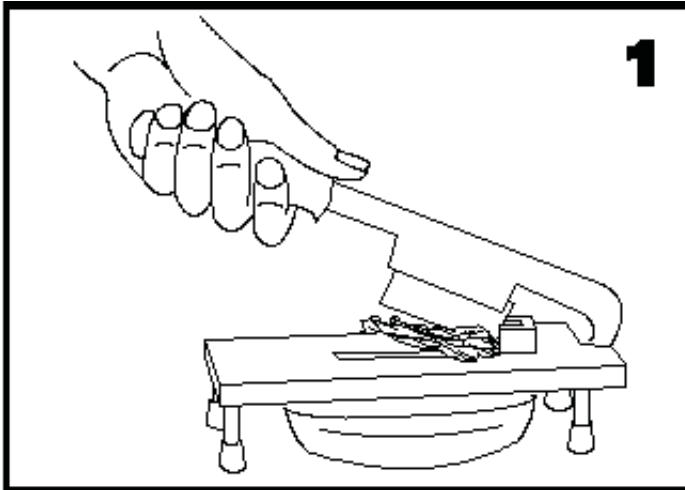

1. Cut the sample into 2mm snippets using either the guillotine supplied or the optional minicore.
2. Spread the fibre snippets onto the open glass slide using the automatic spreader.
3. Load the slide into the OFDA.
4. Press M for Measure and enter the sample name. The OFDA measures 4000 fibres in about 30 seconds.
5. Brush the slide clean. Of course, with the 40 slides supplied you can cut and spread while the OFDA is measuring: this means no delays.